

## Limited Warranty

G2

Products manufactured by Walrus Pumps Co (Walrus) are warranted to the first user only to be free of defects in material and workmanship for a period of 12 months from date of installation, but no more than 24 months from date of shipment. Walrus' liability under this warranty shall be limited to repairing or replacing at our election, without charge, FOB Walrus' distribution center or authorized service agent. Walrus will not be liable for any cost of removal, installation, transportation or any other charges that may arise in connection with warranty claim.

The warranty period commences on the date of original purchase of the equipment. Proof of purchase and installation date, failure date, and supporting installation data must be provided when claiming repairs under warranty.

This warranty is subject to due compliance by the original purchaser with all directions and conditions set out in the installation and operating instructions. Failure to comply with these instructions, damage or breakdown caused by fair wear and tear, negligence, misuse, incorrect installation, inappropriate chemicals or additives in the water, inadequate protection against freezing, rain or other adverse weather conditions, corrosive or abrasive water, lightning or high voltage spikes or through unauthorized persons attempting repairs are not covered under warranty.

Walrus will not be liable for any incidental or consequential damages, losses, or expenses, arising from installation, use, or any other causes. There are no express or implied warranties, including merchantability or fitness for a particular purpose, which extend beyond those warranties described or referred to above.

Certain states do not permit the exclusion or limitation of incidental or consequential damages or the placing of limitations on the duration of an implied warranty, therefore, the limitations or exclusions herein may not apply. This warranty sets forth specific legal rights and obligations, however, additional rights may exist, which may vary from state to state.

Supersedes all previous publications



# WALRUS®

## Walrus America Inc

9808 Whithorn Drive, Houston, TX 77095

Web: [www.walrusamerica.com](http://www.walrusamerica.com)

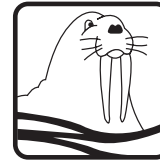

# WALRUS®

## TQ Series

### Electronic Control Pump Instruction Manual



ISO 9001 Certified

## Walrus America Inc

P099C019U200-02

# EC Declaration of Conformity

Manufacturer:

Walrus Pump Co., Ltd.

Address:

No. 83 -14, Dapiantou, Sanjhih Township, Taipei County 252,  
Taiwan

Declare that the machinery described:

Name : Water Pump

Model : TQ Series

Conform to the following directive:

98/37/EC-----Machinery directive

2006/95/EC—Low voltage directive

2004/108/EC----EMC (Electromagnetic compatibility) directive

Refer to the following standards:

EN ISO 12100-1:2003      EN ISO 12100-2:2003

EN1050:1996

EN60335-1:2001      EN 809:1998

EN60335-2-41:2001

EN61000-6-2      EN61000-6-3

R&D department manager: Kao Tien-chuan

Manager: *Kao Tien chuan*

## **TQ Series Instruction Manual**

Please read all instructions carefully before installing your new systems, as failures caused by incorrect installation or operation are not covered by the warranty.

### **I. Product**

The TQ series are designed for the pumping of non-aggressive water, or water not containing solid particles.

### **II. Operating conditions:**

1. Ambient temp. : Max. +104°F (40°C)
2. Liquid temp. : +39°F(4°C) ~ +104°F(40°C)Max.
3. System pressure: Max. 120 PSI
4. Relative humidity: Max. 85%(RH)

### **III. Installation**

1. The pump foundation should be rigid enough to absorb any vibration from the motor, and the pump should be securely bolted to the foundation.
2. It is recommended that the plumber/installer provides an adequate draining system to avoid damage in case of leakage, particularly when installed indoors. When it is installed outside, it should be covered by a weather-proof housing, well ventilated to allow motor heat to escape.
3. Connect the suction pipe to the side and discharge pipe on the top.
4. When use with water heaters, a check valve should be installed between pump (discharge) pipeline and water heater (suction) to avoid high-pressure steam backflow.
5. It is required to shut off the pump when the liquid source is unavailable; although it has the dry run cut off function.
6. The pump has a built-in check valve. Please do not install any other valve on the suction.
7. For TQ1500/2200/3700, Please cut out the center of the rubber gasket inside the inlet and outlet flanges as it will block the water flow.

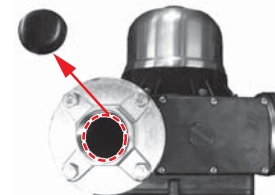

8. When performing regular maintenance, the prime cover has to open in order to check the condition of the check valve. DO NOT apply any bonded material (such as silicon, glue etc) to seal the chamber cover (see drawing below).

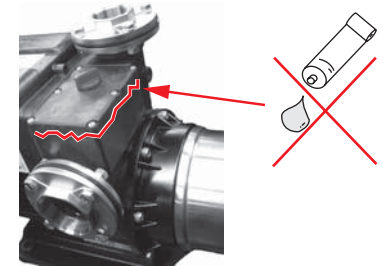

### **IV. Piping**

1. The suction line should be installed as short and straight as possible, with a minimum of bends. The internal diameter of the suction pipe must be equal to, or greater than the ports of the pump.
2. The connection between the suction line and pump must be airtight, and the suction pipe must be positioned so it has an upward slope to the pump (thus avoiding the formation of air pockets).
3. If it is likely the water supply may contain solid particles such as leaves, sand, a filter should be installed before the pump to avoid blocking of water ways.
4. If hose is used as the suction pipe, it must be non-collapsible.
5. To minimize pressure drop, the discharge pipe should be at least the same size as the discharge port of the pump.
6. For long suction pipes or high suction lifts over 13 ft, the suction pipe should be of greater diameter than the suction port.
7. Ensure all connections are completely sealed using thread tape only.

### **V. Connections to Water Source**

#### **1. Flooded Suction – from cistern or storage tank**

No pressure adjustment is required. Recommend to install a bypass valve so water supply can be turned off for pump removal and servicing.

#### **2. Flooded Suction - from city water or pressure tank.**

There will be an inlet pressure added to the pump and is required to satisfy to following two criteria:

- The inlet pressure added to the pump pressure must not exceed 120 psi.
  - The inlet pressure must be 10 psi lower than the max pump pressure.
- When the inlet pressure is higher than the preset starting pressure, it requires adjusting the starting pressure. Please **READ THE WARNING** before adjusting pressure.

The max inlet pressure is as follows

Model	Max inlet pressure	Max pump pressure
TQ200	21	31
TQ400	30	40
TQ800	53	67
TQ1500	48	58
TQ2200	50	60
TQ3700	48	72

**WARNING:**

- **The inlet pressure will add to the pump pressure.** When the total system pressure exceeds the local code limits for home pressure, it is required to install a pressure reducing valve to reduce the inlet pressure. Too high system pressure will also endanger your pipe systems.
- **Pressure adjustment WILL NOT change the pump discharge pressure.**
- When inlet pressure is inconsistent (for example from 20 to 50 psi), recommend to install a pressure reducing valve to avoid total system pressure exceeding the limit.

**3. Suction Lift - below ground water sources**

Whenever the installation position of the pump is higher than 3ft above the lowest water level, a foot valve must be installed on the end of suction pipe.

- Please refer to the factory preset starting pressure and max pressure as follows:

The factory preset starting pressure

Model	Power (HP)	Prest pressure (psi)
TQ200	1/4	20
TQ400	1/2	28
TQ800	1	36
TQ1500	2	43
TQ2200	3	43
TQ3700	5	43

The TQ maximum pressure .

Model	Maximum Pressure ( psi )
TQ200	31
TQ400	40
TQ800	67
TQ1500	58
TQ2200	60
TQ3700	72

**VI. Electrical connection**



This mark located outside the connection box is a warning for an electrical hazard.

1. Ensure the mains voltage is the same as the value shown on the motor plate and that the pump is safely connected to ground/earth.
2. The single phase models are supplied with plug and lead and can be connected directly to the mains supply. The 3 phase models should hook up with a circuit breaker.

**VII. Wiring diagram**

**WARNING:**

**Risk of Electric Shock - This pump is supplied with a grounding conductor and grounding-type attachment plug. To reduce the risk of electric shock, be certain that it is connected only to a properly grounded, grounding-type receptacle".**

Before operation, please ensure the voltage is correct and the circuit breaker and grounding connectors are all connected in accordance with local regulations.

**Single-phase power supply**

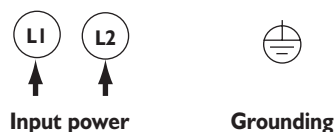

**3-phase power supply (check if rotation is correct)**

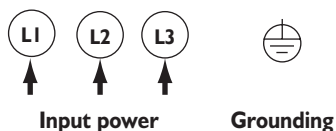
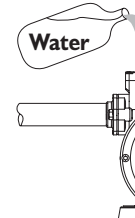
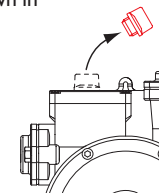

Fig. 1

**VIII. Starting**

1. Before starting, the pump must be primed. Please follow the procedure as shown in Fig 3.

**a. Remove the filling plug**



**b. Fill water in chamber**

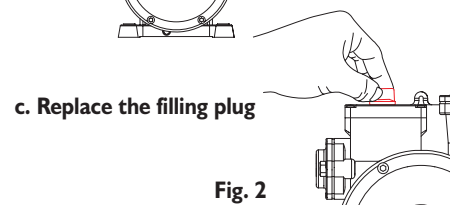

**c. Replace the filling plug**

Fig. 2

2. Installation where the pump inlet is below the water supply, remove the priming plug and allow the water to flow into the priming chamber until all air is expelled.
3. The priming procedure should be repeated until all air is expelled and the pump delivers a full stream of water without air bubbles.
4. The pump must always be checked for prime if not used for a prolonged period. It is imperative to fill the pump with liquid before operation as dry running causes irreparable damage to the mechanical seal.
5. When 3-phase motor is supplied, please ensure if the rotation is correct. You can switch any of the 2 wires to get your desired rotation.

**IX. Precautions**

1. The pump should be shut down and the trouble corrected if the pump is running at speed and found to have any of the following problems:
  - No liquid discharged - Not enough liquid discharged
  - Excessive vibration - Motor runs hot
2. Do not allow the pump to continually start and stop (cycling) as this will reduce the motor life.
3. Cycling can occur on pressure units when the pressure tank pre-charge drops, or where there is a leak in the discharge plumbing.

**X. Operation and maintenance**

Under normal operating conditions, the pump does not require any maintenance as long as the following points are observed:

1. Periodically check the condition of the check valve and strainer (if used). motor shaft as shown in Fig 3 and turn to free the rotor. If this does not remedy the problem, the unit will need dismantling.
2. If the pump is to be inactive for long periods, it should be rinsed thoroughly with clean water, then, drained and stored in a dry place. It has to be re-primed before start-up.
3. If the pump rotor is seized up after periods of inactivity, please place a screw driver from the motor end to rotate the rotor. It should free the pump rotor.

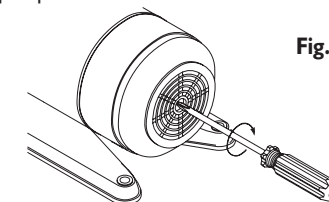

Fig. 3

4. Pressure tank air charge should be checked at regular intervals of every 3 months and after the pump has not been used for a prolonged period. To check the Pressure Tank air pressure, turn off power, open a tap on the discharge line to release pressure from the pump, unscrew the black plastic cover and apply an accurate pressure gauge to the valve as shown in Fig 4. Pressure should be adjusted to the original pre-charge as follows:
  - TQ200: 17 psi (1.2 Kg/cm<sup>2</sup>)
  - TQ400: 26 psi (1.8 Kg/cm<sup>2</sup>)
  - TQ800: 36 psi (2.5 Kg/cm<sup>2</sup>)
  - TQ1500 up to TQ3700: 36 psi (2.5 Kg/cm<sup>2</sup>)

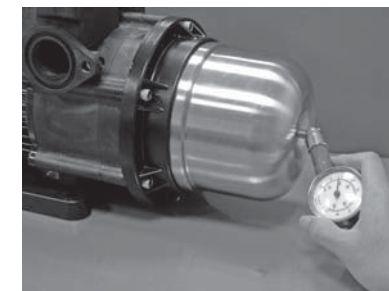

Fig. 4

## Fllooded Suction Performance Table

### TQ200

Inlet pressure (psi)	Flow rate				
	3 gpm	6 gpm	9 gpm	12 gpm	15 gpm
5	32	27	22	17	10
10	37	32	27	22	15
15	42	37	32	27	20
** 20	47	42	37	32	25

\*\* Need to adjust pressure switch setting when inlet pressure is higher than the preset activation point (TQ200 preset at 17 psi)

### TQ400

Inlet pressure (psi)	Flow rate					
	3 gpm	6 gpm	9 gpm	12 gpm	15 gpm	18 gpm
10	48	42	37	30	23	15
20	58	52	47	40	33	25
** 30	68	62	57	50	43	35

\*\* Need to adjust pressure switch setting when inlet pressure is higher than the preset activation point (TQ400 preset at 26 psi)

### TQ800

Inlet pressure (psi)	Flow rate						
	3 gpm	6 gpm	9 gpm	12 gpm	15 gpm	18 gpm	21 gpm
10	73	69	63	57	49	39	27
20	83	79	73	67	59	49	37
30	93	89	83	77	69	59	47
** 40	103	99	93	87	79	69	57

\*\* Need to adjust pressure switch setting when inlet pressure is higher than the preset activation point (TQ800 preset at 36 psi)

### TQ1500

Inlet pressure (psi)	Flow rate					
	10 gpm	20 gpm	30 gpm	40 gpm	50 gpm	60 gpm
10	63	59	55	48	39	27
20	73	69	65	58	49	37
30	83	79	75	68	59	47
40	93	89	85	78	69	57

### TQ2200

Inlet pressure (psi)	Flow rate					
	10 gpm	20 gpm	30 gpm	40 gpm	50 gpm	60 gpm
10	66	62	58	53	46	36
20	76	72	68	63	56	46
30	86	82	78	73	66	56
40	96	92	88	83	76	66

### TQ3700

Inlet pressure (psi)	Flow rate					
	10 gpm	20 gpm	30 gpm	40 gpm	50 gpm	60 gpm
10	80	75	70	65	59	49
20	90	85	80	75	69	59
30	100	95	90	85	79	69
40	110	105	100	95	89	79

## XI. Adjust pressure switch

Adjust the pressure switch setting (according to the pump models) as shown in Fig 5. Make sure the system is primed.

The pump is supplied with a preset pressure in the pressure switch. For most applications, it will be satisfactory. In some cases a different pressure may be required. This can be achieved by following the instructions below. However, it is highly recommended that the adjustment is only done by the professional personnel.

Instructions for pressure adjustment (Fig. 5):

1. If pump does not start when tap is on, adjust clockwise ("+" ) till it starts.
2. If pump does not stop when no water is consumed, adjust counterclockwise ("-") till it stops.
3. After adjustment is made, turn it on and off several times to make sure it operates normally.

### TQ 200/400/800

Open the cover to adjust the pressure

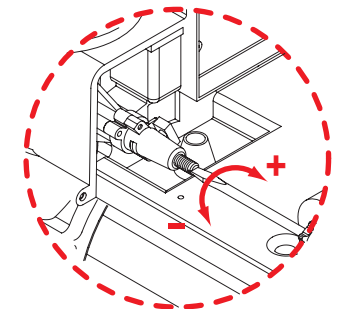
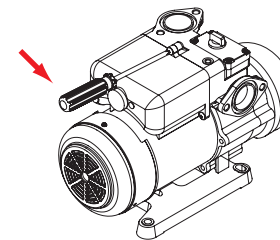
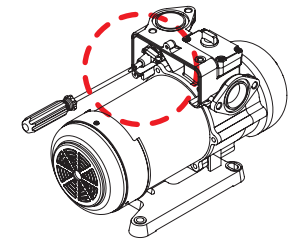
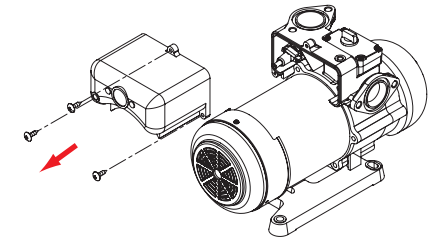

## TQ 1500/2200/3700

Open the cover to adjust the pressure

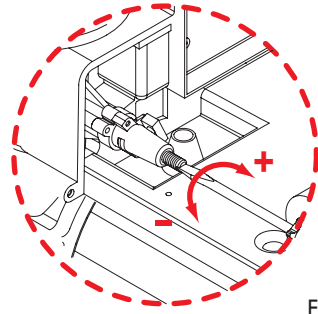
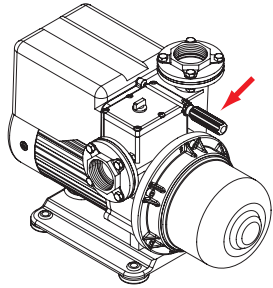

Fig. 5

### XII. Adjust flow switch

Following the adjustment of the pressure switch, and with the unit running, close all tapes on the discharge. If the pump cuts out, no adjustment is necessary. If the pump does not cut off, please refer to Fig 6:

1. For TQ200/400/800: Loose the hex. screw and use a screw driver to adjust the flow switch clockwise (+) until the pump stops.
2. For TQ1500/2200/3700: Open the control box and move the flow level control to a higher position (to allow more flow) until the pump stops.

Open and close a tap on the discharge several times to ensure that the pump starts and stops normally. No further adjustments are necessary.

### TQ 200/400/800

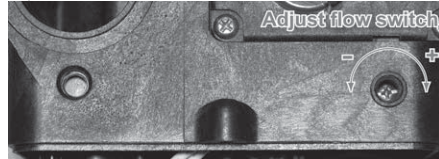

### TQ 1500/2200/3700

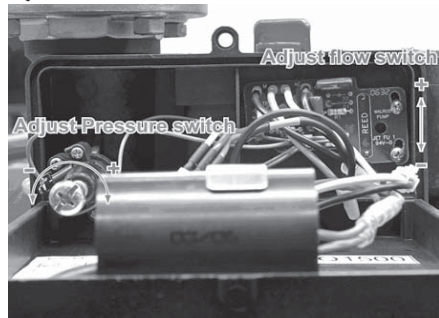

Fig. 6

### Warning

The pump is not designed for continuous operation under low discharge flows such as slow closing float valves, slow running taps. Under this application, please install an extra tank of adequate volume to avoid “cycling”. (Fig7)

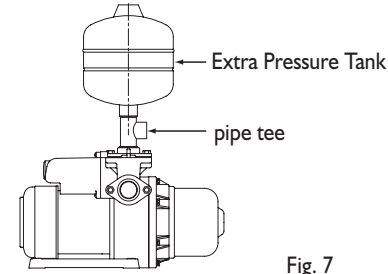

Fig. 7

Please set the extra pressure tank pressure the same as activation pressure. Leaking discharge line and leaking taps will damage the unit through causing the pump to repeatedly start and stop.

### XIII. Frequently asked questions:

1. What causes the TQ to start?

The TQ has the built-in pressure switch and internal flow switch. Each of these can turn the pump on depending on water consumption. The pump will start when:

- The pressure is BELOW the pressure switch activation point. OR
- The flow rate is greater than 0.7 GPM.

The preset activation point for each model is provided in the pump specifications. The cut in pressure must be lower than the preset activation pump; otherwise the pump will not start.

2. What causes the TQ to stop?

The flow switch is designed to automatically stop the TQ pump when flow drops to below 0.7 GPM. The pump will shut off in a few seconds after flow stops (TQ200-800 is programmed to stop after 8 seconds and TQ1500-3700 is programmed to stop after 15 seconds). In addition, the TQ will be turned off in the event of dry-run or over temperature alarm.

3. What is the purpose of the built-in pressure tank? The pressure tank comes from the factory pressurized at approximately 17-36 psi (with the pump pressure at zero). It is designed to minimize motor startup due to small flow demand or minor leak of the pipeline.

TQ200 - 17 psi (1.2 Kg/cm <sup>2</sup> )
TQ400 - 26 psi (1.8 Kg/cm <sup>2</sup> )
TQ800 - 36 psi (2.5 Kg/cm <sup>2</sup> )
TQ1500 up to 3700 - 36 psi (2.5 Kg/cm <sup>2</sup> )

4. How is the dry-run condition determined and the protection provided?

The dry-run is defined when the motor is running AND the flow rate is less than 0.3 GPM AND when pressure is less than the pressure switch setting. The protection is provided:

When the pump is run dry 2 minutes, it will automatically shut off for 10 minutes and then attempts to restart. When all 3 attempts are failed, the pump will rest for 1 hour and then attempts to restart. This protection mode will be repeated until the water supply is back to normal.

In case the pump is cycling (on-and-off repeatedly) due to small flow (less than 0.3GPM), air pocket in the system, air loss in the pressure tank or leak in the pipeline, the protection is provided: The pump will run for 8 seconds and stop for about 3 seconds. When the cycling mode repeat for 15 times consecutively, the pump will be rest for 1 hour. Then it will start over the protection mode until the problem is corrected.

**Note:** Above unusual pump shutdown, users may remove power plug over than 6 seconds and reconnect again to restart, if it is necessary.

#### XIV. Dimensions: (in.)

##### TQ200/400/800

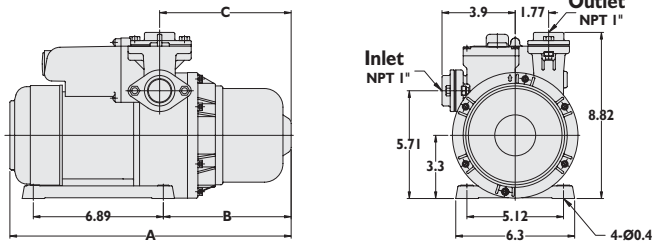

##### TQ1500/2200/3700

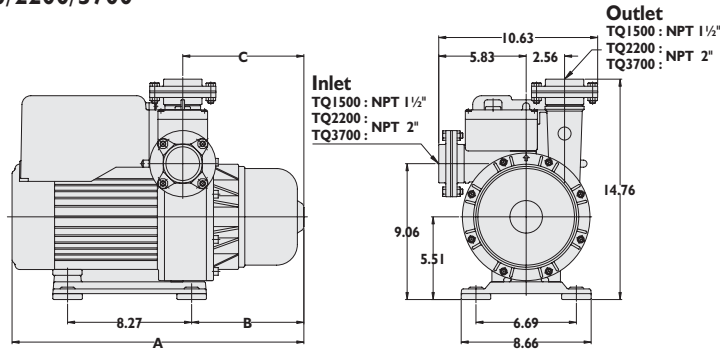

Model	A (in.)	B (in.)	C (in.)
TQ 200	14.37	6.26	6.46
TQ 400	14.92	6.77	6.97
TQ 800	17.76	7.80	7.99
TQ1500~3700	19.72	7.76	8.35

#### XV. Specification:

Model	Power (HP)	Cycle (Hz)	Phase (Ø)	Voltage (V)	Amp's (A)	Inlet (NPT)	Outlet (NPT)	H max. (ft)	Q max. (GPM)
TQ200	¼	60	I	115 or 230	4.0 or 2.0	1"	1"	72	16.9
TQ400	½	60	I	115 or 230	6.0 or 3.0	1"	1"	92	18.5
TQ800	1	60	I	115 or 230	11.0 or 5.5	1"	1"	154	23.8
TQ1500	2	60	I or 3	230	9.5 or 6.5	1½"	1½"	134	66.0
TQ2200	3	60	3	230	9.5	2"	2"	138	71.3
TQ3700	5	60	3	230	12	2"	2"	167	71.3

#### XVI. Troubleshooting



Before starting work on the pump, make sure that the electricity supply has been switched off and that it cannot be accidentally switched on.

Problem	Cause	Remedy
1. pump does not start	a. No power supply	Connect the electricity supply
	b. Too low/high voltage	Check if souply voltage is within $\pm 10\%$
	c. Inadequate pressure at suction or discharge	Follow V and XI of the Operation Manual
	d. Seized-up pump	Place a screwdriver against the shaft end of the motor to check it the rotor will spin freely, and contact your pump supplier.
2. Pump cuts out during operation	a. Seized-up pump	Same as above
	b. Overloaded motor	Turn off the power supply and restart or contact your pump supplier.
	c. Poor water supply	Check if pump suction inlet is blocked.
	d. The protection for pump dry run or cycling is activated.	Check the detailed information per XIII (Frequently asked questions). Item 5
3. Pump starts when no water is consumed	a. Existing pipe is leaking	Fix the leakage.
	b. Air tank pressure is too low	Charge air per X-4 of the manual.
	c. Pipe suck in air.	Check the suction pipe and water supply.
4. Pump starts and stops too frequently	a. Leakage in suction pipe or air in the water.	Check the suction pipe and water supply.
	b. Discharge flow is too low.	Set your tap on a higher water flow.
5. Electric shock	a. Ineffective grounding	Reactivate grounding.
6. Pump does not stop when water is not consumed	a. Poor water supply or air suck in.	1. Turn off the power supply and open the refilling plug to release the air. Then restart. 2. In case of long suction pipes, turn off the power and make sure if water supply is adequate.
	b. Pressure set is too high	Adjust pressure per XI
	c. Flow set is too small.	Adjust flow switch per XII
	d. Defective check valve.	Clean or replace with a new valve.
7. Pump runs normal but with very low discharge flow	a. 3-phase motor runs in wrong rotation.	Switch any of the 2 wires from motor terminal to correct rotation.
	b. Poor water supply	check if water supply is adequate and if the suction pipe is blocked.