



# ITT

Residential Water Systems

## Goulds Pumps Deep Well Packer Adapter

For use with Jet Pumps

### TYPICAL INSTALLATIONS

---

#### Horizontal Jet Pumps

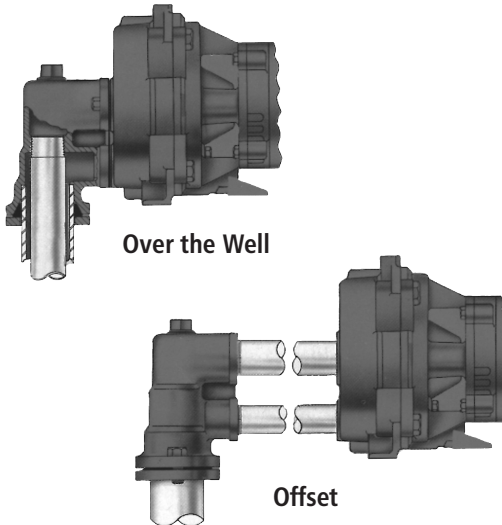

#### Vertical Jet Pumps

With AWD Adapter

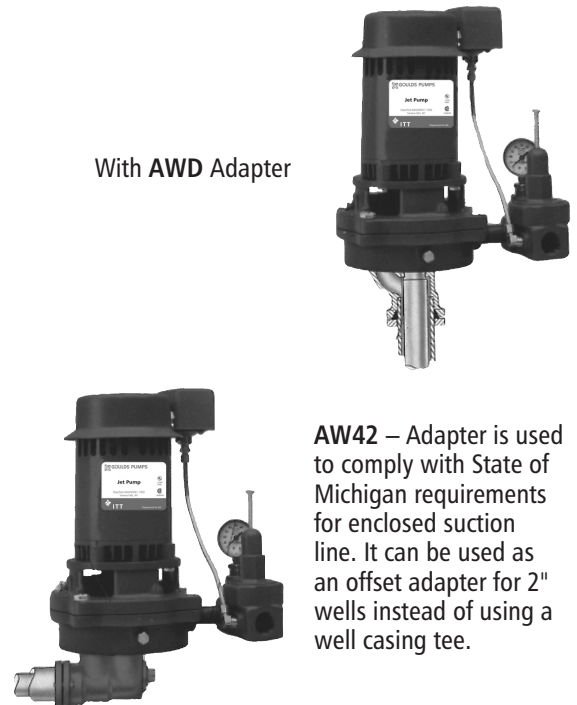

**AW42** – Adapter is used to comply with State of Michigan requirements for enclosed suction line. It can be used as an offset adapter for 2" wells instead of using a well casing tee.



Goulds Pumps is a brand of ITT Corporation.

[www.goulds.com](http://www.goulds.com)

*Engineered for life*

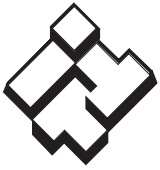

# ITT

## Residential Water Systems

### WELL HEAD FITTINGS



■ **AWJ2 – 2" Packer Adapter:** Well casing adapter for series J+, JRD and HSJ jet pumps.

■ **AW40\*:** Well casing adapter for series J+, JRD and HSJ jet pumps.



■ **AWJB2 – 2" Packer Adapter:** Well casing adapter for series JB jet pumps.

■ **AWD2 or AWD3:** Well casing adapter for series SJ and VJ jet pumps.



■ **AWCJ3 – 3" Packer Adapter:** Well casing adapter for series J+ and HSJ.

■ **AW42\*\*:** Well casing adapter for series SJ and VJ jet pumps.



■ **SRPA:** Converts Goulds Pumps SJ to Sta-Rite® 2" packer.



## GOULDS PUMPS

Goulds Pumps and the ITT Engineered Blocks Symbol are registered trademarks and tradenames of ITT Corporation.

Sta-Rite is a registered trademark of Pentair.

SPECIFICATIONS ARE SUBJECT TO CHANGE WITHOUT NOTICE.

**BDWPA June, 2007**

© 2007 ITT Corporation

*Engineered for life*

\*AW40 is used to comply with State of Michigan requirements for offset installations from 2" or 3" diameter wells.

\*\*AW42 can be used to comply with State of Michigan requirements for offset installations from 2" or 3" diameter wells.

AW42 cannot be used as well casing adapter for 3" diameter wells.