

OWNERS GUIDE TO INSTALLATION AND OPERATION

FW0078
0508
Supersedes
0407

READ THESE INSTRUCTIONS CAREFULLY

Read these installation instructions in detail before installing your pump. Be sure to check the following:

1. Be certain the motor is connected for the correct line voltage being used (check motor nameplate).
2. Be certain the pump is completely primed before starting. Otherwise damage may occur to the seal.

Every pump is tested before leaving the factory, and its performance depends largely on the installation.

END SUCTION CENTRIFUGAL PUMPS

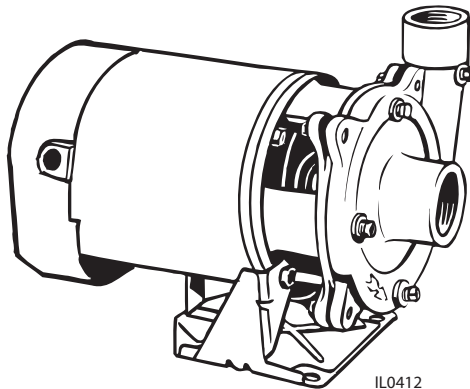

Figure 1 - CJ103 Series

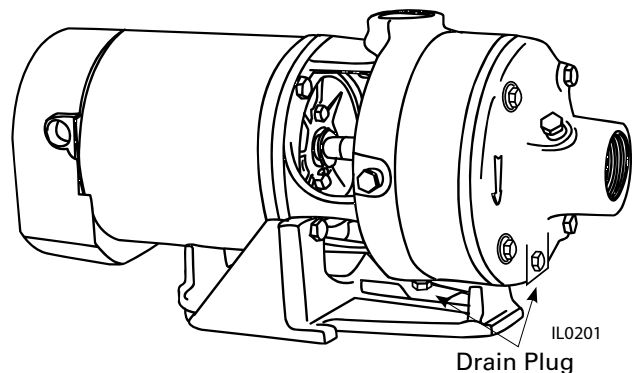

Figure 2 - CJ101 Series

GENERAL SAFETY INFORMATION

1. Follow all local electrical and safety codes, as well as the National Electrical Code (NEC) and the Occupational Safety and Health Act (OSHA).
2. Replace damaged or worn wiring cord immediately.
3. Do not kink power cable and never allow the cable to come in contact with oil, grease, hot surfaces or chemicals.
4. Protect the power cable from coming in contact with sharp objects.
5. Be careful when touching the exterior of an operating motor - it may be hot enough to be painful or cause injury.
6. Make certain that the power source conforms to the requirements of your equipment.
7. Always disconnect power source before performing any work on or near the motor or its connected load. If the power disconnect point is out-of-sight, lock it in the open position and tag it to prevent unexpected application of power. Failure to do so could result in fatal electrical shock.

8. Do not handle the pump with wet hands or when standing in water as fatal electrical shock could occur. Disconnect main power before handling unit for ANY REASON!
9. Unit must be securely and adequately electrically grounded. This can be accomplished by wiring the unit to a ground metal-clad raceway system or by using a separate ground wire connected to the bare metal of the motor frame or other suitable means.
10. **▲ WARNING** Risk of electric shock. This pump has not been investigated for use in swimming pool areas.
11. **▲ WARNING** This product contains chemicals known to the State of California to cause cancer and birth defects or other reproductive harm.

NOTE: Pumps with the "CSA" mark are tested to UL standard UL778 and certified to CSA standard C22.2 No. 108.

Dimensions (In Inches) CJ103 Series

Chart A

HP	A	B	C	D	E	F	G	H	J	K
1/3	4	4-5/8	3-11/16	4-13/16	9-3/16	2-1/2	8-1/4	8-1/8	13-1/4	3-7/8
1/2	4	4-5/8	3-11/16	4-13/16	9-3/16	2-1/8	8-1/4	8-1/8	13-1/2	3-7/8
3/4	4	4-5/8	3-11/16	4-13/16	9-3/16	2-1/8	8-1/4	8-1/8	14	3-7/8
1	4	4-5/8	3-11/16	4-13/16	9-3/16	2-1/8	8-1/4	8-1/8	14-1/2	3-7/8
1-1/2	4	4-5/8	3-11/16	4-13/16	9-3/16	2-1/8	8-1/4	8-1/8	15-1/8	3-7/8
2	4	4-5/8	3-11/16	4-13/16	9-3/16	2-1/8	8-1/4	8-1/8	15-5/8	3-7/8

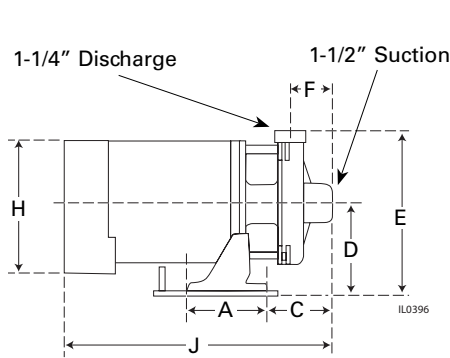

Figure 3 - CJ103 Single Stage Booster Pump

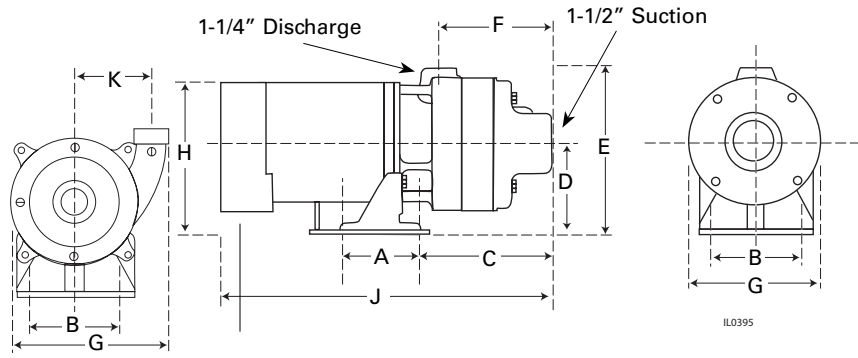

Figure 4 - CJ101B Two and Three Stage Booster Pump

CJ101 Series

Chart B

HP	A	B	C	D	E	F	G	H	J
3/4	4	4-5/8	7-9/16	4-13/16	8-3/4	6-1/4	7	8-1/8	17-7/8
1	4	4-5/8	7-9/16	4-13/16	8-3/4	6-1/4	7	8-1/8	18-3/8
1-1/2	4	4-5/8	7-9/16	4-13/16	8-3/4	6-1/4	7	8-1/8	19
2	4	4-5/8	7-9/16	4-13/16	8-3/4	6-1/4	7	8-1/8	19-1/2
2 *	4	4-5/8	9-7/16	4-13/16	8-3/4	8-1/8	7	8-1/8	21-3/8
3 *	4	4-5/8	9-7/16	4-13/16	8-3/4	8-1/8	7	8-1/8	21-3/8

(*) Three Stage

Motor Data

HP	PH	VOLTS	HZ	RPM	MOTOR VOLTAGE (FACTORY) CONNECT.	SERVICE FACTOR MOTOR AMPS				LOCKED ROTOR AMPS				KVA
						SINGLE PHASE		THREE PHASE		SINGLE PHASE		THREE PHASE		
						115V	230V	230V	460V	115V	230V	230V	460V	
1/3	1	115/230	60	3450	115V	8.6	4.3	—	—	26.0	13.0	—	—	K
1/2	1	115/230	60	3450	115V	13.0	6.5	—	—	36.0	18.0	—	—	K
3/4	1	115/230	60	3450	115V	14.0	7.0	—	—	52.0	26.0	—	—	K
1	1	115/230	60	3450	230V	18.0	9.0	—	—	70.0	39.0	—	—	L
1-1/2	1	115/230	60	3450	230V	21.0	10.5	—	—	98.0	49.0	—	—	J
2	1	115/230	60	3450	230V	25.0	12.5	—	—	116.0	58.0	—	—	H
3	1	230	60	3450	230V	—	13.5	—	—	—	53.0	—	—	D
3/4	3	208-230/460	60/50	3450/2850	230V	—	—	3.5	1.75	—	—	19.0	9.5	K
1	3	208-230/460	60/50	3450/2850	230V	—	—	4.5	2.25	—	—	26.9	13.5	K
1-1/2	3	208-230/460	60/50	3450/2850	230V	—	—	5.7	2.85	—	—	33.5	16.8	K
2	3	208-230/460	60/50	3450/2850	230V	—	—	7.4	3.0	—	—	44.0	22.0	K
3	3	208-230/460	60	3450	230V	—	—	9.8	4.9	—	—	48.0	24.0	D

Typical Installations

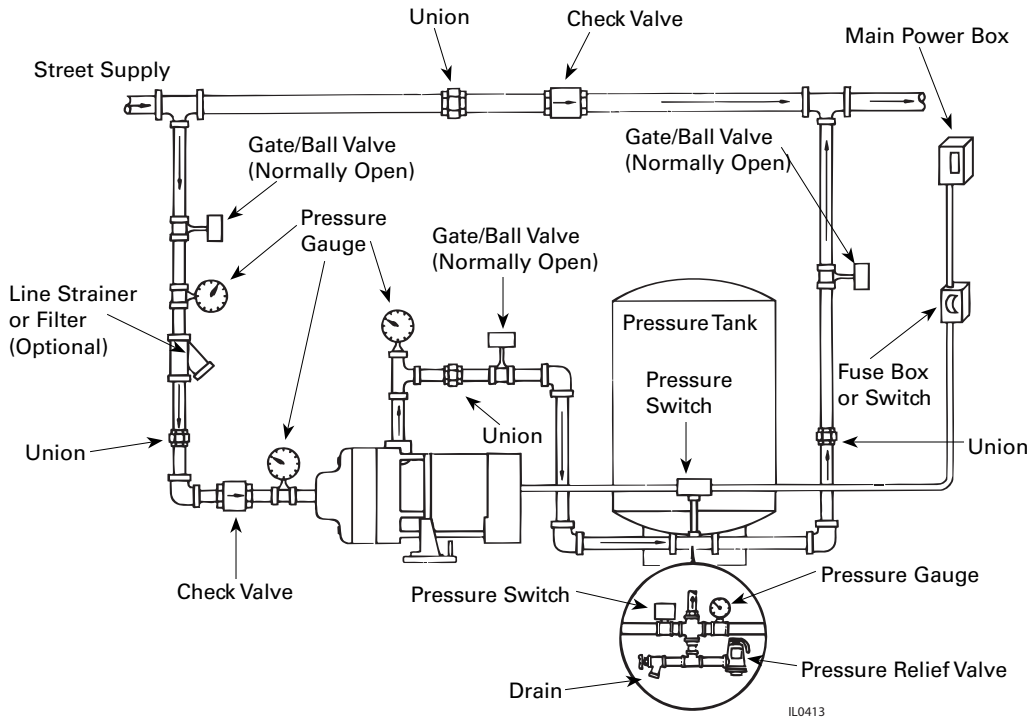

To size pressure tank properly, match the drawdown of the tank to the capacity of the pump.

(*) For manual operation, omit the pressure tank and pressure switch. Wire motor direct to fuse box.

WARNING Install a pressure relief valve on any installation where pump pressure can exceed the pressure tank's maximum working pressure or on systems where the discharge line can be shut off or obstructed. Extreme over pressure can result in personal injury or property damage.

Figure 5

To size pressure tank properly, match the drawdown of the tank to the capacity of the pump.

(*) For manual operation, omit the pressure tank and pressure switch. Wire motor direct to fuse box.

WARNING Install a pressure relief valve on any installation where pump pressure can exceed the pressure tank's maximum working pressure or on systems where the discharge line can be shut off or obstructed. Extreme over pressure can result in personal injury or property damage.

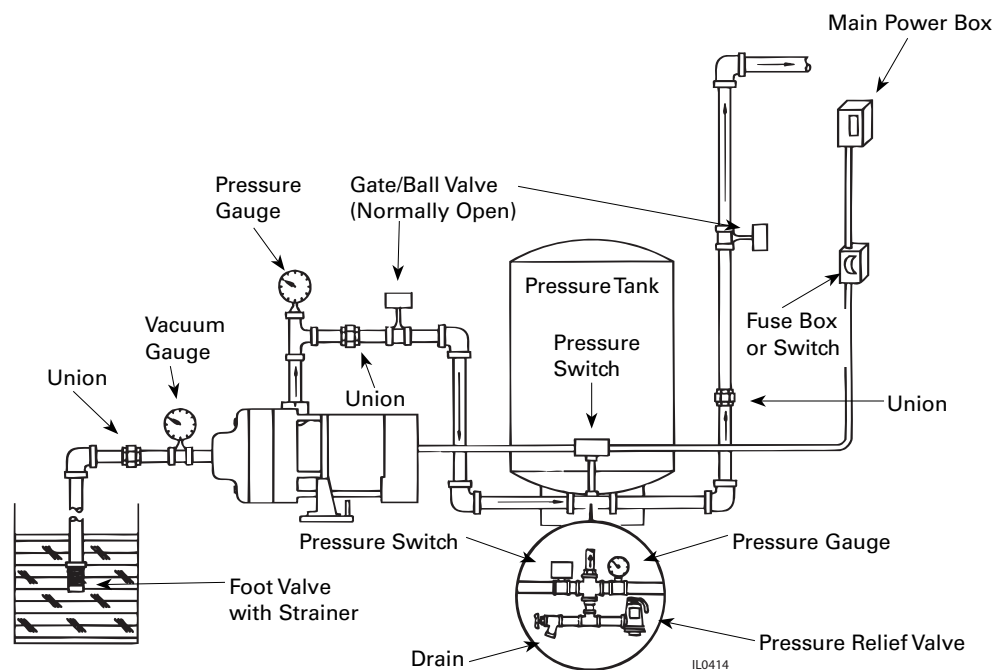

Figure 6

Pump Performance

Chart D

Single Phase Model No.	Three Phase Model No.	HP	Stage	GPM at Total Pressure in PSI†											Max. Press. PSI	◆Max. Case Press. PSI	◆Max. Liquid Temp.	
				15	20	25	30	35	40	50	60	70	80	90				
BRASS IMPELLER MODELS																		
CJ103031	-	1/3	1	41	30	10										27	100	200°F
CJ103051	CJ103053	1/2	1	48	40	27										30	100	200°F
CJ103071	CJ103073	3/4	1	62	58	46	31									33	100	200°F
CJ103101	CJ103103	1	1	70	66	58	48	34								40	100	200°F
CJ103151	CJ103153	1-1/2	1	*	75	70	61	51	36							44	100	200°F
CJ103201	CJ103203	2	1	*	*	79	77	68	57							45	100	200°F
CJ101B071	CJ101B073	3/4	2	*	*	32	29	25	22	5						53	160	200°F
CJ101B101	CJ101B103	1	2	*	*	35	32	29	27	23	3					62	160	200°F
CJ101B151	CJ101B153	1-1/2	2	*	*	42	39	37	34	28	19					68	160	200°F
CJ101B201	CJ101B203	2	2	*	*	45	44	43	40	34	26					70	160	200°F
CJ101C201	CJ101C203	2	3	*	*	42	41	40	38	35	31	27	20	7		93	160	200°F
CJ101C301	CJ101C303	3	3	*	*	51	50	49	43	41	40	35	29	21		95	160	200°F
THERMOPLASTIC IMPELLER MODELS																		
CJ101P071	CJ101P073	3/4	2	*	*	31	28	23	20							48	160	160°F
CJ101P101	CJ101P103	1	2	*	*	34	31	30	29	19						60	160	160°F
CJ101P151	CJ101P153	1-1/2	2	*	*	46	44	41	37	31	14					61	160	160°F
CJ101P201	CJ101P203	2	2	*	*	45	44	42	39	31	21					65	160	160°F
CJ101D201	CJ101D153	2	3	*	*	41	40	38	37	33	29	24	17			89	160	160°F
CJ101D301	CJ101D303	3	3	*	*	*	46	45	45	42	38	33	27	18		93	160	160°F

† To convert to feet of head, multiply by 2.31.

* Operation of pump in this range may result in motor damage.

◆ Do not exceed the maximum case pressure and maximum liquid temperature rating of the pump.

Suction & Discharge Tapping: 1-1/2" X 1-1/4"

Motor Voltage: Single phase: 1/3 - 115V; 1/2 thru 2 HP - 115/230V; 3 HP - 230V, 60HZ
 Three phase: 1/2 thru 2 HP - 208-230/460V - 50/60HZ
 3 HP - 208-230/460V - 60HZ

INSPECTION AND STORAGE

When unpacking the unit, inspect carefully for any damage that may have occurred during shipment. If the unit is received sometime before it can be used, it should be inspected, recreated and stored in a dry location.

LOCATION

IMPORTANT: In installations where property damage might result from an inoperative or leaking pump due to power outages, discharge line blockage or any other reason, a back-up system (s) and/or warning system (s) should be used. Install a gate valve and union in the suction and discharge lines. For removal of the pump for service, close the gate valve and disconnect the union.

1. Locate pump as close to the fluid source as possible.
2. Place unit where the motor electrical components and piping are protected from the weather and extremes of heat, humidity and below freezing temperatures.
3. Mount unit in a dry location that is easily accessible for inspection and maintenance. If a dry location is not available, mount it on a foundation well above the wet floor.

4. Allow ample clearance around unit for free air circulation.
5. CJ103 Series pumps incorporate a discharge port on the pump casing that can be adjusted in 90 increments. If necessary, adjust the discharge port to accommodate the specific application. Pump performance will not be affected by the position of the discharge port.

SUCTION LIMITATIONS

1. Units are non self-priming. Normally after being primed the total suction lift of the pump is 25 feet. Suction lift varies depending upon elevation (altitude) and water temperature. See Practical Suction Lift chart.
2. Where liquids at or near their boiling points are being handled, the supply must be located above the suction, so that the available NPSH will be greater than that required by the unit.

Practical Suction Lifts at Various Elevations and Water Temperatures in Degrees Fahrenheit

Altitude	60°	80°	100°	120°	140°	160°	180°	200°
Sea Level	-22	-21	-20	-18	-15	-10	-4	+5
2000	-20	-19	-18	-16	-12	-7	-1	+8
4000	-17	-16	-15	-13	-10	-4	+2	+12
6000	-15	-14	-13	-11	-7	-2	+6	+16
8000	-13	-12	-10	-8	-4	+2	+9	—
10000	-10	-9	-8	-6	-2	+4	+13	—

This table gives the maximum permissible suction lift or the minimum head permitted on the suction side of a pump at various altitudes and liquid temperatures. A minus sign before a number indicates suction lift. A plus sign before a number indicates minimum head. These figures are to be used as a guide.

PIPING

1. Use galvanized piping, rigid plastic or other suitable pipe that will not collapse under suction or rupture due to pressure.
2. The diameter of the suction and discharge pipe should be no smaller than the corresponding tappings of the pump (see Figure 3 & 4). If long runs are encountered larger pipe should be used. Smaller pipe will reduce the capacity of the pump.
3. All joints and connections should have Teflon tape or pipe sealing compound (male threads only) applied and drawn up tightly.

CAUTION *The entire system must be air and water tight for efficient operation.*

PUMP INSTALLATION

Refer to Figures 5, 6, and 7 for typical installations. Both the suction and discharge pipe should be supported at a point near the pump to avoid strains being placed on the pump.

1. If the pump is used as part of a permanent installation, secure to a rigid foundation with appropriate fasteners.
2. Locate the pump as close to the water as possible, keeping the suction pipe as short as conditions permit.
3. Avoid dips or pockets in offset piping or air will accumulate at high points which will make priming difficult.
4. The suction pipe should slope upward to the pump inlet. A horizontal suction line must have a gradual rise to the pump.

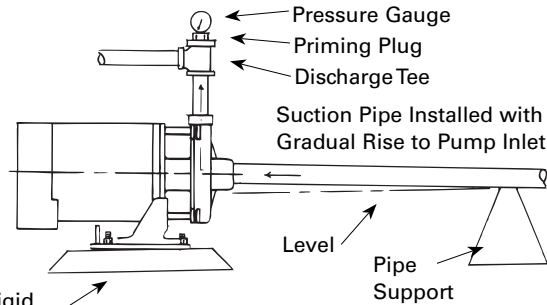

Figure 7

5. On suction lift installations, a foot valve located in the water or a check valve located as close to the water as possible will reduce priming time of the pump and help maintain prime. A strainer must be used on the suction line to filter out dirt and debris.
6. A priming tee installed in the pump discharge port allows water to be poured into the pump case and suction piping, which is required for priming on suction lift installations.
7. Install a gate valve and union in the suction and discharge lines. For removal of the pump for service, close the gate valve and disconnect the union.
8. Pressure Gauges - Properly sized vacuum or pressure gauges can be installed in both the suction and discharge pipe. The gauges will enable observation of the pump's performance as well as detecting cavitation, vapor binding or other unstable operation.

CAUTION *Do not use a globe valve or other restricting type of valve at the discharge. This will seriously restrict the capacity of the pump.*

CAUTION *Use only components that are rated higher than shut-off pressure of the system. Do not exceed the pump's maximum case pressure as listed in the following table.*

Models	Maximum Case Pressure
CJ103	100 PSI
CJ101	160 PSI

WARNING *A pressure relief valve of adequate capacity must be installed on any installation where the pump pressure can exceed the pressure tank's maximum working pressure or on systems where the discharge line can be shut-off or obstructed. Not providing a relief valve can cause extreme over pressure which could result in personal injury and/or property damage.*

ELECTRICAL

⚠ WARNING



Hazardous voltage. Can shock, burn or cause death. Failure to follow warnings can cause fatal or severe shock hazard or equipment failure.



Ground motor before connecting to electrical power supply.



Connect the motor frame to equipment grounding conductor by using green screw. Do not connect green ground wire to any of the motor leads.



Do not ground to a gas supply line.



Turn off power to motor before working on electrical connections.



Supply voltage must be within $\pm 10\%$ of nameplate voltage. If in doubt consult a licensed electrician.



Use wire size specified in wiring Chart E. If possible, connect pump to a separate branch circuit with no other appliances on it. If wiring diagram on motor model plate differs from diagram shown in figures 8, 9 & 10, follow diagram on motor.

All wiring should be performed by a qualified electrician and in accordance with the national and local electric codes.

WIRING

- Motor voltages will vary depending upon the motor horsepower and phase. Refer to the motor nameplate and the Motor Data Chart (Chart C) for voltage and electrical data.

⚠ WARNING *Make certain that the power supply conforms to the electrical specifications of the motor supplied. Failure to do so may cause premature motor failure and will void the warranty.*

- To change voltage, remove the rear access cover, which is held in place with two (2) screws. For proper electrical connection, refer to the connection diagram located on the motor

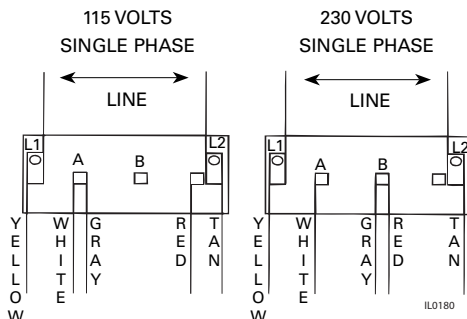

Figure 9 - Wiring Diagram for Single Phase
1/3-2 HP

nameplate or figures 8, 9 & 10.

⚠ WARNING *Replace rear access cover before starting or operating pump. Failure to do so can result in personal injury.*

MOTOR PROTECTION

- All single phase motors have built in thermal protection for all voltages. The overload protects the motor against burnout from overload of low voltage, high voltage and other causes. The device is automatic and resets itself once the temperature has dropped to a safe point. Frequent tripping of the device indicates trouble in the motor or power lines and immediate attention is needed.

⚠ WARNING *Never examine, make wiring changes or touch the motor before disconnecting the main electrical supply switch. The thermal device may have opened the electrical circuit.*

- Three phase motors do not have a built in thermal protection. It is recommended that a properly sized magnetic or manual starter (both with properly sized heaters) be used with all three phase motors. Install starters following instructions of the starter manufacturer. See Figure 11 for magnetic starter wiring diagram.
- All motors (single and three phase) should be equipped with a correctly fused disconnect switch to provide protection. consult local or national electric codes for proper fuse protection based on motor data chart (see Charts C & E).

PRIMING

- Before starting any centrifugal pump, it is absolutely necessary that both the casing and suction pipe be completely filled with liquid. This priming can be accomplished by any of the following methods:
- When the liquid supply level is above the center line of the pump, it is primed by opening the suction and discharge valves. The inflowing liquid will displace the air and fill the suction

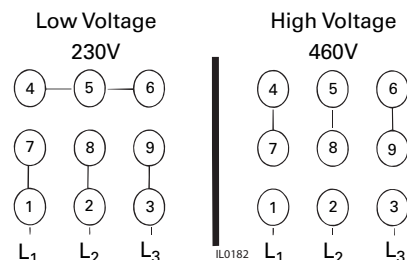

Figure 10 - Wiring Diagram for Three Phase

line, pump casing, and discharge line up to the level of supply.

3. Where the pump is operating with suction lift and the suction line is equipped with a foot valve, remove the priming plug from the discharge tee (see Figures 5-8) and fill the pump body and suction pipe completely with water. No additional water will be needed for subsequent start-ups unless the pump body is drained.
4. After the pump is turned on it will require 2-5 minutes before all air is evacuated from the suction line and water begins to flow. If there is no water after 5 minutes, turn the pump off and check the following:
 5. Any air leaks on the suction line must be eliminated.
 6. Suction pipe inlet should be a minimum of 5 feet below the water level.
 7. Total suction lift cannot be greater than 25 feet.
 8. Any restrictions in the discharge pipe, such as a closed valve must be eliminated.

NOTE: Unit must be full of liquid before operating. Never run dry, or against a closed discharge. Dry running or running unit against a closed discharge will cause damage to the shaft seal. Do not pump dirty water or abrasive liquids, otherwise the same may occur as if running dry.

MOTOR ROTATION

1. Single phase models are one (1) rotation only (counterclockwise when facing the pump suction tapping) and cannot be reversed.

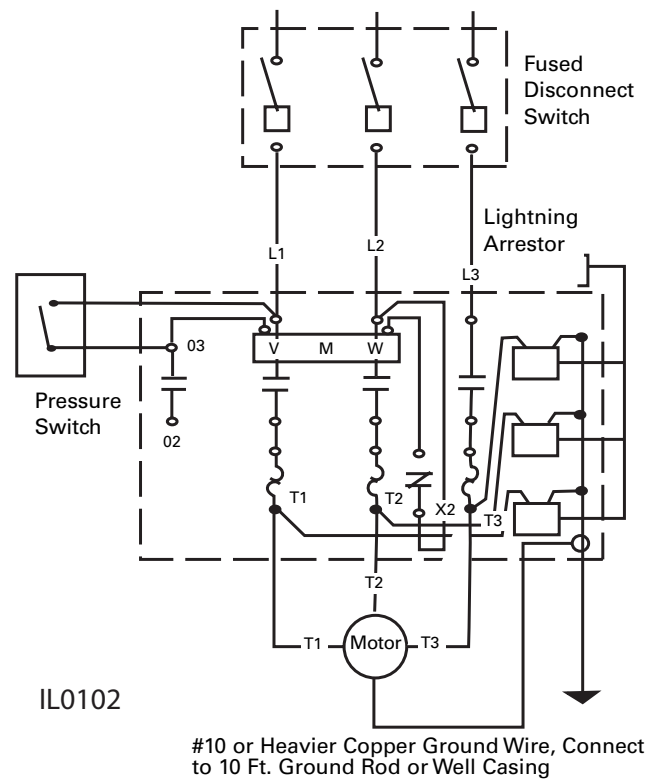
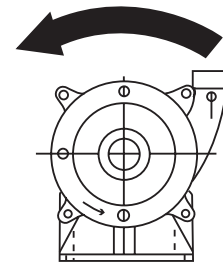

Figure 11 - Magnetic Starter Wiring Diagram Three Phase

2. Proper rotation of pump impeller is critical for three phase pumps. Pump motor should turn counterclockwise (CCW) when facing pump suction tapping. Momentarily “bump” (apply power for less than a second) the motor to check for proper rotation. To change rotation on three phase units, interchange any two (2) incoming line (power) leads.



IL0416

Figure 12 - Correct Motor Rotation

Chart E

DISTANCE FROM MOTOR TO FUSE BOX METER, OR ELECTRICAL OUTLET	MINIMUM COPPER WIRE SIZE CHART (GAUGE)																						
	SINGLE PHASE MOTORS							THREE PHASE MOTORS															
	1/3 HP	1/2 HP	3/4 HP	1 HP	1-1/2 HP	2 HP	3 HP	3/4 HP	1 HP	1-1/2 HP	2 HP	3 HP											
0-50'	14	14	12	14	12	14	10	14	10	12	10	12	10	14	14	14	14	14	14	14	14	14	14
50-100'	14	14	12	14	12	14	10	14	8	12	8	12	10	14	14	14	14	14	14	14	14	14	14
100-150'	14	14	12	14	10	14	10	12	6	12	6	12	10	14	14	14	14	14	14	14	14	14	14
150-200'	12	14	12	14	10	12	8	12	*	10	*	10	10	14	14	14	14	12	14	12	14	12	14
200-300'	12	14	10	14	8	12	6	10	*	10	*	10	8	14	14	12	14	12	14	10	12	10	12
Breaker Size (Amps)	15	15	20	15	20	15	30	15	30	20	30	20	30	15	15	15	15	15	15	15	15	15	15

(*) Not economical to run in 115 volt, use 230 volts

MAINTENANCE

Lubrication

The pumps and motors require no lubrication. The ball bearings of the motor have been greased at the factory. Under normal operating conditions they should require no further greasing.

Winterizing your Pump

Cracked pump housings caused by freezing are not covered by warranty. To protect your pump from freezing, for best results remove the pump and store in a warm environment. If pump cannot be removed from your system, remove both drain plugs, one on the suction flange and one at the bottom rear of the pump (see fig 2 in the instructions.) Allow the water to completely drain from the pump. Re-install both drain plugs and fill pump with RV type antifreeze. Antifreeze also acts as a rust inhibitor. It will help keep rust build up to a minimum and seals lubricated inside the pump while it is not in use.

ROTARY SEAL ASSEMBLY REPLACEMENT

Disassembly

CAUTION When disassembling the pump, care should be taken not to damage the gaskets. If torn or damaged, replace with new gasket (see parts list).

1. Remove the four (4) pump through bolts that connect the mounting ring to the pump body. Remove the pump body, taking care not to damage the gasket or o-ring.
2. Remove the impellers. CJ103 Models are single stage units, having one impeller. Using a 9/16" open end wrench, hold the motor shaft flat and unthread the impeller by turning it counterclockwise. The motor shaft flat area is located in the middle of the mounting ring.
3. CJ101 models are multi stage units, having two or more impellers and one or more intermediate stages. Using an 11/16" open end wrench on the motor shaft extension flat, remove the first impeller by turning or

counterclockwise. Remove the intermediate stage (stages) taking care not to damage the gasket (gaskets) and unthread the remaining impellers.

4. Remove the mechanical seal assembly. The rotary portion of the seal assembly (carbon ring, Buna-N gasket and spring) will easily slide off the end of the shaft. The ceramic portion can be pried out of the rubber seating using two (2) screwdrivers (see Figure 13).

Reassembly

CAUTION The precision lapped faces of the mechanical seal are easily damaged. Handle the replacement seal carefully. Short seal life will result if seal faces (ceramic & carbon) are nicked, scratched or dirty.

1. Clean the seal cavity of the mounting ring and the motor shaft thoroughly.
2. Apply liquid soap (one drop only) to the outside of the Buna-N gasket that houses the ceramic seal seat. With thumb pressure, press the ceramic seat, polished face up, squarely into the seal cavity (see Figure 14).
3. If seal does not seat squarely, remove and reclean the seal cavity. Place a cardboard washer over the polished seal face and carefully press into place using a piece of pipe or tubing (see Figure 15). Discard cardboard washer.
4. Apply liquid soap (one drop only) to the inside diameter of the rubber drive ring. Slip rubber drive ring (carbon face down) and the spring over the shaft.
5. Reassemble the pump by following the reverse order of the disassembly instructions.

MOTOR REPLACEMENT

1. Nema J motors can be replaced in the field with any standard Nema J jet pump motor by referring to the following instructions and the attached parts list.

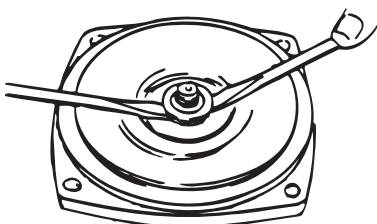

IL0173

Figure 13 - Remove Mechanical Seal

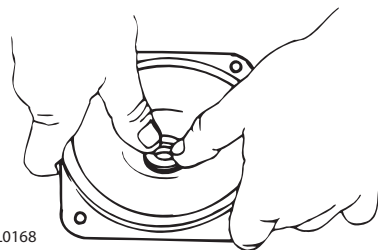

IL0168

Figure 14 - Press in Seal

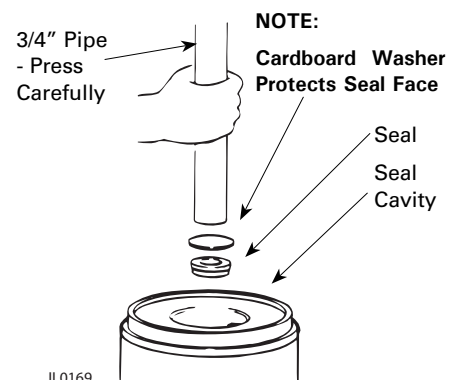

IL0169

Figure 15 - If Necessary, Press with Cardboard and Pipe

2. Follow steps as outlined under Rotary Seal Replacement to remove the pump body, diffuser, impeller and rotary seal.
3. Remove bolts that connect the motor to the mounting ring and pull motor away.
4. Replace motor with standard Nema J jet pump motor by positioning motor against the mounting frame and assembling with four (4) 3/8" x 3/4" cap screws. The mounting base is

connected at the bottom of the mounting frame with two (2) 3/8" x 1/2" cap screws.

5. Follow steps of Rotary Seal Assembly to reassemble the remainder of the pump.

BECAUSE DAMAGE TO THE SHAFT SEAL IS MOST LIKELY TO OCCUR IN DISASSEMBLY, A NEW SEAL WILL BE NECESSARY.

Troubleshooting Chart		
Symptom	Possible Cause(s)	Corrective Action
Little or no discharge	<ol style="list-style-type: none"> 1. Pump not primed 2. Total head too high 3. Suction head higher than pump designed for 4. Impeller clogged 5. Incorrect rotation 6. Leak in suction line 7. Inadequate foot valve 8. Impeller damaged 9. Foot valve or suction line not submerged deep enough in water 10. Insufficient inlet pressure or suction head 11. Wrong size piping 12. Casing gasket leaking 13. Suction or discharge line valves closed 	<ol style="list-style-type: none"> 1. Prime unit 2. Shorten suction lift and/or discharge head 3. Lower pump inlet 4. Clean 5. Refer to wiring information 6. Repair or replace 7. Make needed adjustments 8. Replace 9. Submerge lower in water 10. Increase inlet pressure by adding more fluid to fluid source 11. Make needed adjustments 12. Replace gasket 13. Open
Loss of suction	<ol style="list-style-type: none"> 1. Air leak in suction line 2. Suction head too high 3. Insufficient inlet pressure or suction head 4. Clogged foot valve or strainer 	<ol style="list-style-type: none"> 1. Repair 2. Lower pump inlet 3. Increase inlet pressure by adding more fluid to fluid source 4. Clean or replace
Pump vibrates and/or makes excessive noise	<ol style="list-style-type: none"> 1. Mounting plate or foundation not rigid enough 2. Foreign material in pump 3. Damaged impeller 4. Cavitation present 5. Worn motor bearings 6. Bent impeller shaft 	<ol style="list-style-type: none"> 1. Reinforce 2. Clean 3. Replace 4. Check suction line for proper size and be certain valve is open. Remove excessive loops in suction line 5. Replace 6. Replace
Pump will not start or run	<ol style="list-style-type: none"> 1. Improperly wired 2. Blown fuse or open circuit breaker 3. Loose or broken wiring 4. Impeller clogged 5. Motor shorted out 	<ol style="list-style-type: none"> 1. Refer to wiring diagram 2. Replace fuse or close circuit breaker 3. Tighten connections and replace broken wiring 4. Clean 5. Replace
Pumps leaks at shaft	<ol style="list-style-type: none"> 1. Worn mechanical seal 2. Bent impeller shaft 	<ol style="list-style-type: none"> 1. Replace 2. Replace

CENTRIFUGAL PUMP REPAIR PARTS "CJ103" SERIES (For Pricing Refer To Repair Parts Price List)

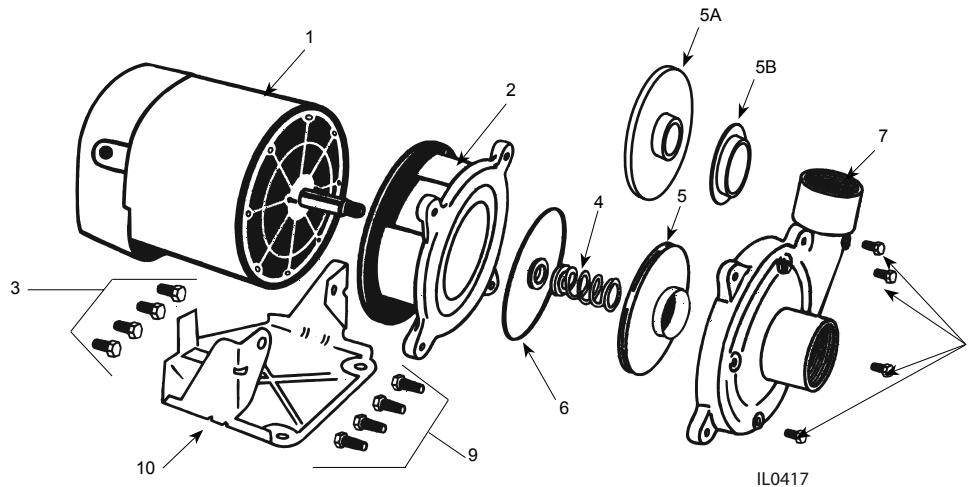

		HP	1/3	1/2	3/4	1	1-1/2	2
		STAGE	1	1	1	1	1	1
ITEM	SINGLE PHASE BRASS IMPELLER	MODEL NO.	CJ103031	CJ103051	CJ103071	CJ103101	CJ103151	CJ103201
	THREE PHASE BRASS IMPELLER			CJ103053	CJ103073	CJ103103	CJ103153	CJ103203
	SINGLE PHASE PLASTIC IMPELLER		CJ103P031	CJ103P051	CJ103P071	CJ103P101	CJ103P151	CJ103P201
	SINGLE PHASE PLASTIC IMPELLER			CJ103P053	CJ103P073	CJ103P103	CJ103P153	CJ103P203
	DESCRIPTION	PART NO.	QTY.					
1	Motor, Nema J - 1PH		98J103	98J105	98J107	98J110	98J115	98J120
1	Motor, Nema J - 3 PH		—	98J305	98J307	98J310	98J315	98J320
	Motor Access Cover	021301R	1	1	1	1	1	1
	Screws, Access Cover	021302	2	2	2	2	2	2
‡	Slinger Washer	126905	1	1	1	1	1	1
2	Mounting Ring	134107	1	1	1	1	1	1
3	Hex Hd. Cap Screws 3/8 x 3/4"	*	4	4	4	4	4	4
4	Seal, Rotary w/Spring	131100	1	1	1	1	1	1
5	Impeller - Brass		130403	126900	127805	127804	127806	127848
5A	Impeller - Plastic		133426	139222	021380	135248	021279	N/A
5B	Clearance Ring		N/A	138138	134240	134240	134240	N/A
6	Ring, Square Cut †	132583	1	1	1	1	1	1
7	Body Assembly - Brass Impeller		127870	127870	127780	127780	127780	127780
	Body Assembly - Plastic Impeller	021439	1	1	1	1	1	N/A
‡	Suction Clearance Ring-Brass		127869A	127869A	125842A	125842A	125842A	125842A
8	Pipe Plugs, 1/8" NPT	*	4	4	4	4	4	4
9	Hex Hd. Cap Screws 3/8 x 1"	*	4	4	4	4	4	4
10	Base	125855	1	1	1	1	1	1

(*) Standard hardware item

(‡) Not shown

(†) For pumps with paper gasket, replace with part number 127782

(Δ) Kit Includes: Access Cover, Screws & Wiring Diagrams

CENTRIFUGAL PUMP REPAIR PARTS "CJ101" SERIES (For Pricing Refer To Repair Parts Price List)

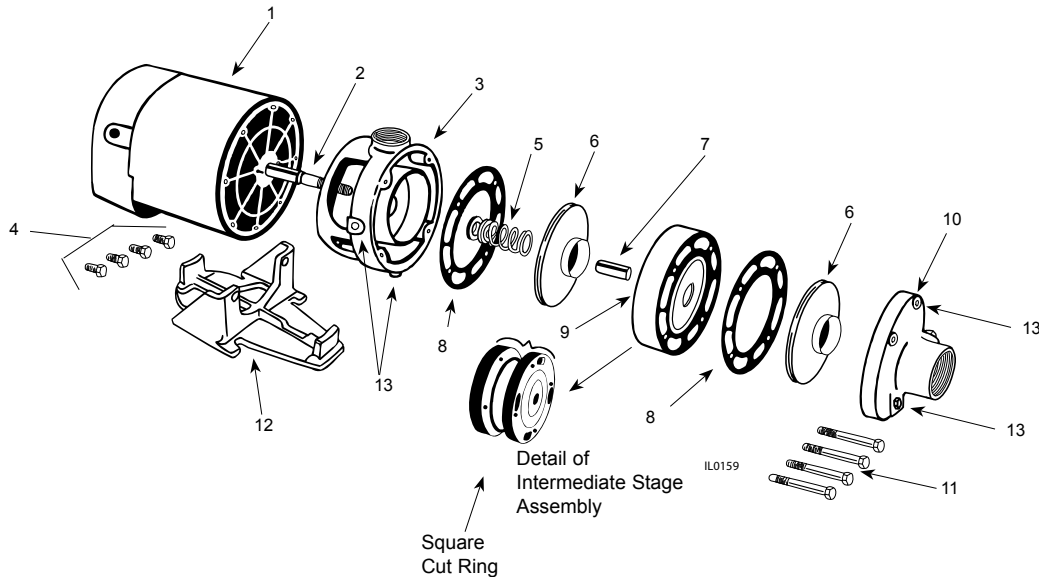

		HP	3/4	1	1-1/2	2	2	3
		STAGE	2	2	2	2	3	3
ITEM	SINGLE PHASE - BRASS IMPELLER	MODEL NO.	CJ101B071	CJ101B101	CJ101B151	CJ101B201	CJ101C201	CJ101C301
	THREE PHASE - BRASS IMPELLER		CJ101B073	CJ101B103	CJ101B153	CJ101B203	CJ101C203	CJ101C303
	SINGLE PHASE - PLASTIC IMPELLER		CJ101P071	CJ101P101	CJ101P151	CJ101P201	CJ101D201	CJ101D301
	THREE PHASE - PLASTIC IMPELLER		CJ101P073	CJ101P103	CJ101P153	CJ101P203	CJ101D203	CJ101D303
DESCRIPTION		PART NO.	QTY					
1	Motor, Nema J - 1 PH		98J107	98J110	98J115	98J120	98J120	98J630
1	Motor, Nema J - 3 PH		98J307	98J310	98J315	98J320	98J320	98J330
	Motor Cover w/Screws	021301R	1	1	1	1	1	1
	Screws, Cover	021302	2	2	2	2	2	2
‡	Slinger Washer	126905	1	1	1	1	1	1
2	Shaft		135279A	135279A	135279A	135279A	136612A	136612A
3	Mounting Ring	125204	1	1	1	1	1	1
4	Hex Hd. Cap Screws 3/8 x 3/4"	*	2	2	2	2	2	2
5	Seal, Rotary w/Spring	131100	1	1	1	1	1	1
6	Impeller, Brass		†135280	†135281	†126900	†126901	†139126	†136951
6	Impeller, Thermoplastic		†133425	†133427	†139180	†128472	†133427	†139104
7	Spacer, Shaft	133380	1	1	1	1	2	2
8	Gasket	130968	2	2	2	2	3	3
9	Intermediate Stage Assembly**	131239B	1	1	1	1	2	2
‡	Suction Clearance Ring	130957	1	1	1	1	2	2
‡	Hub Clearance Ring	131282	1	1	1	1	2	2
‡	Square Cut Ring Interm. Stg.	020240	1	1	1	1	2	2
10	Suction Flange Assembly	125227A	1	1	1	1	1	1
‡	Suction Clearance Ring	130957	1	1	1	1	1	1
‡	Suction Bearing	020053	1	1	1	1	1	1
11	Pump thru Bolts 3/8" x 3-1/4"	*	4	4	4	4	--	--
11	Pump thru Bolts 3/8" x 5"		--	--	--	--	4	4
12	Base w/ Bolts 3/8" x 1-1/4"	020054	1	1	1	1	1	1
13	1/4" NPT Plug	*	4	4	4	4	4	4

(*) Standard hardware item
 (†) For quantity required — See number of stages
 (‡) Not shown
 (**) Includes two castings, square cut ring, suction and hub clearance ring - See Detail Drawing
 (Δ) Kit Includes: Access Cover, Screws & Wiring Diagrams